

DE:

Vielen Dank, dass Sie sich für unser Produkt entschieden haben! Uns ist es wichtig, dass der Montageprozess für Sie schnell und einfach verläuft. Deshalb haben wir diese einfache und übersichtliche Anleitung erstellt, die Sie Schritt für Schritt durch den Aufbau führt. Egal, ob Sie das Produkt zum ersten Mal montieren oder bereits Erfahrung haben – wir sind sicher, dass Sie es problemlos schaffen! Viel Erfolg und viel Spaß beim Montieren!

ENG:

Thank you for choosing our product! We want the assembly process to be quick and easy for you. That's why we created this simple and clear guide to take you through each step, one by one. Whether it's your first time assembling this product or you have experience, we're sure you'll manage just fine! Good luck and happy assembling!

PL:



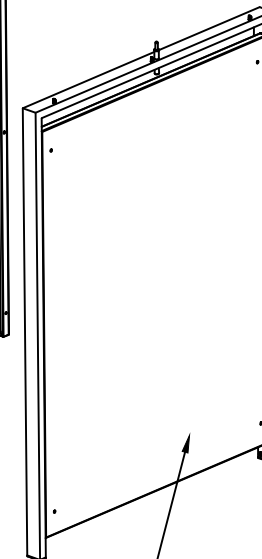
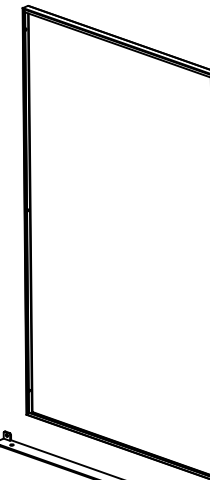
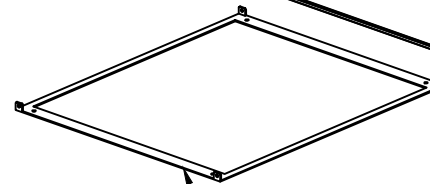
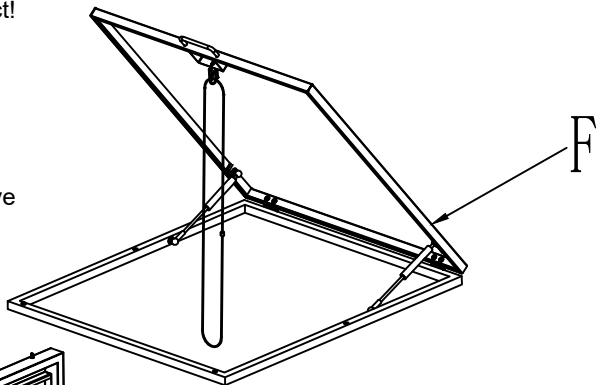
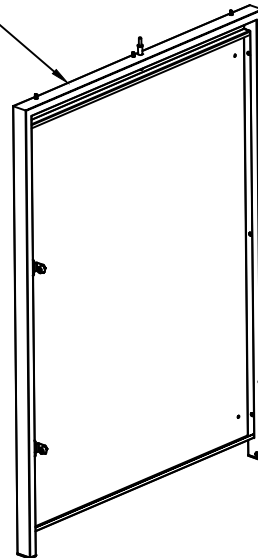
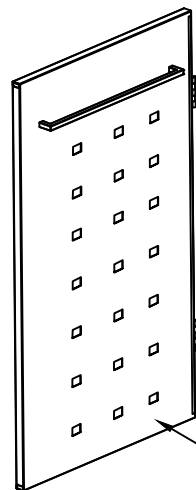
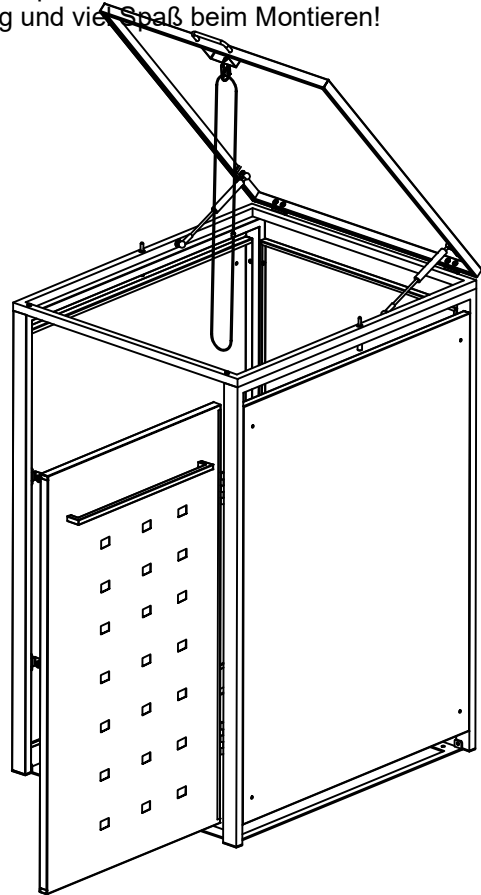







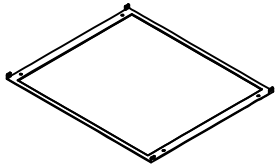
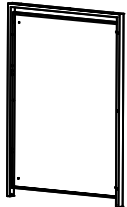
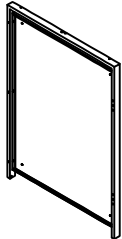
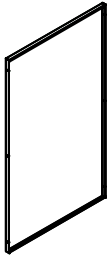
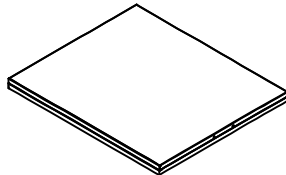
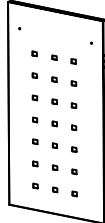
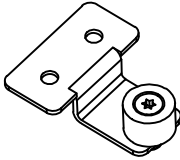
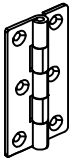
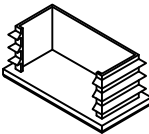

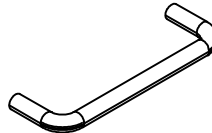
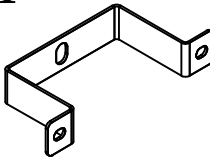
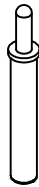
Dziękujemy za wybór naszego produktu! Zależy nam, aby proces montażu przebiegł dla Ciebie szybko i sprawnie. Dlatego stworzyliśmy tę prostą i przejrzystą instrukcję, która krok po kroku poprowadzi Cię przez każdy etap. Bez względu na to, czy montujesz ten produkt po raz pierwszy, czy masz już doświadczenie, z pewnością poradzisz sobie bez problemu! Powodzenia i miłego montowania!

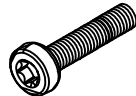

H

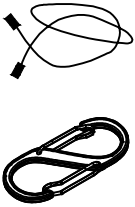
A1

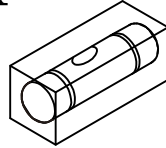
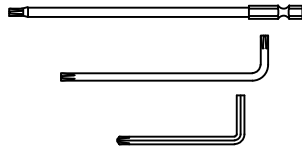
D

A1x1 	Cx1 	Dx1 	Ex1 	F1x1 	Hx1 
I1x2 	Kx2 	Lx4 	Mx1 	Nx1 	Ox1 
Px2 	Qx4 	Rx12 M4*10mm 	Sx6 M4*20mm 	Tx6 M4*30mm 	Ux16 M4*14mm 
Vx1 	Wx4 	Xx4 	Yx1 	Zx1 	
			 PPbin — POLSKIE POJEMNIKI —		

STEP 1

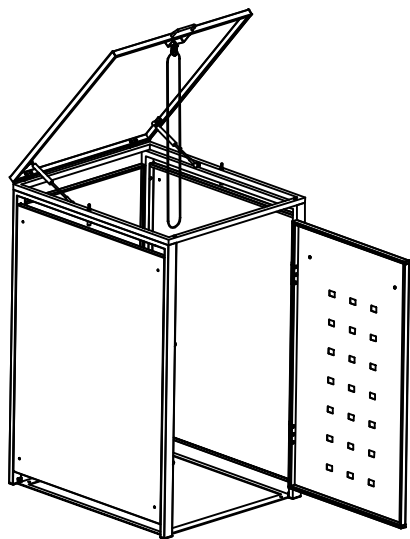
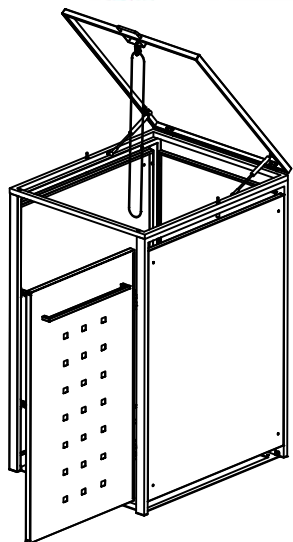

STEP 1:

DE: Legen Sie die Rahmen (2 Stück) mit dem längeren Auge nach unten auf den Boden und achten Sie darauf, dass die Seitenwände – beide müssen an den Rändern sein – korrekt positioniert sind. Befestigen Sie die Einsätze.

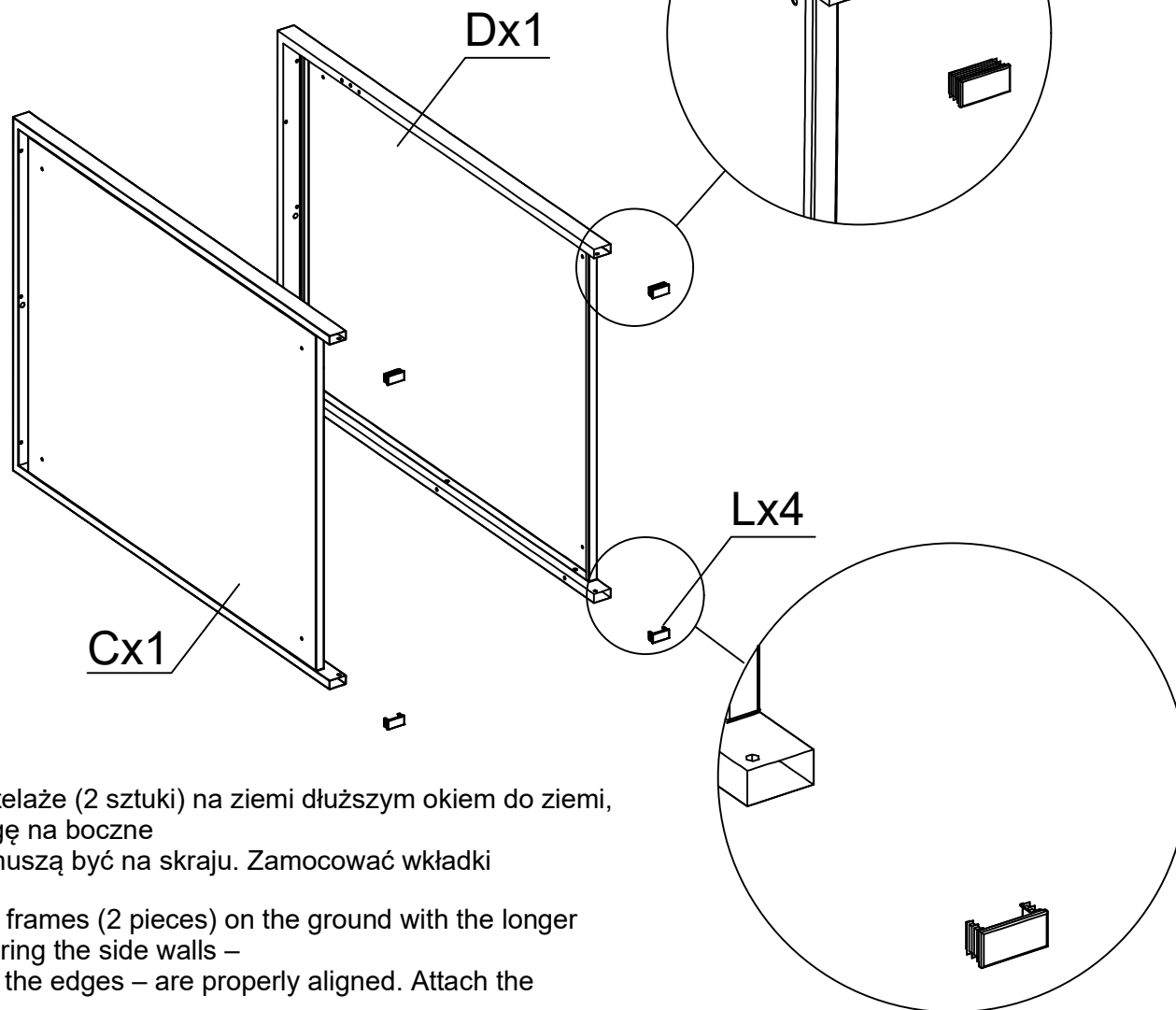

STEP 1:

PL: Umieścić stelaże (2 sztuki) na ziemi dłuższym okiem do ziemi, zwracając uwagę na boczne ścianki – obie muszą być na skraju. Zamocować wkładki

ENG: Place the frames (2 pieces) on the ground with the longer eye down, ensuring the side walls – both must be at the edges – are properly aligned. Attach the inserts.

STEP 2

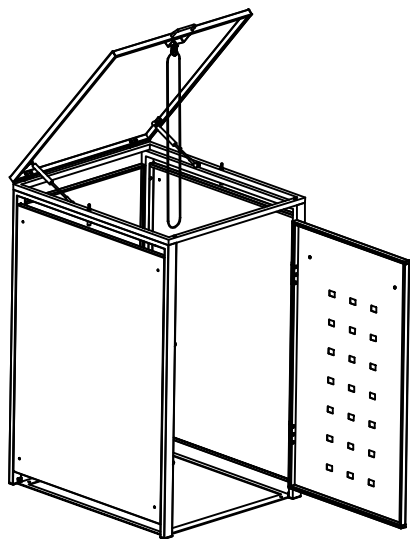
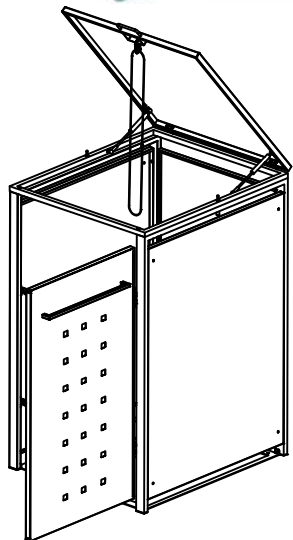

STEP 2:

DE: Befestigen Sie die Magnetelemente (I1x2) am seitlichen Rahmen Cx1 – dies sind die Teile, die die Türen beim Schließen halten.

ENG: Attach the magnetic elements (I1x2) to the side frame Cx1 – these are the parts that will hold the doors when closed.

PL: Do bocznego stelaża Cx1 przymocować element z magnesem I1x2 – to część, która będzie przetrzymywać drzwi podczas zamykania.

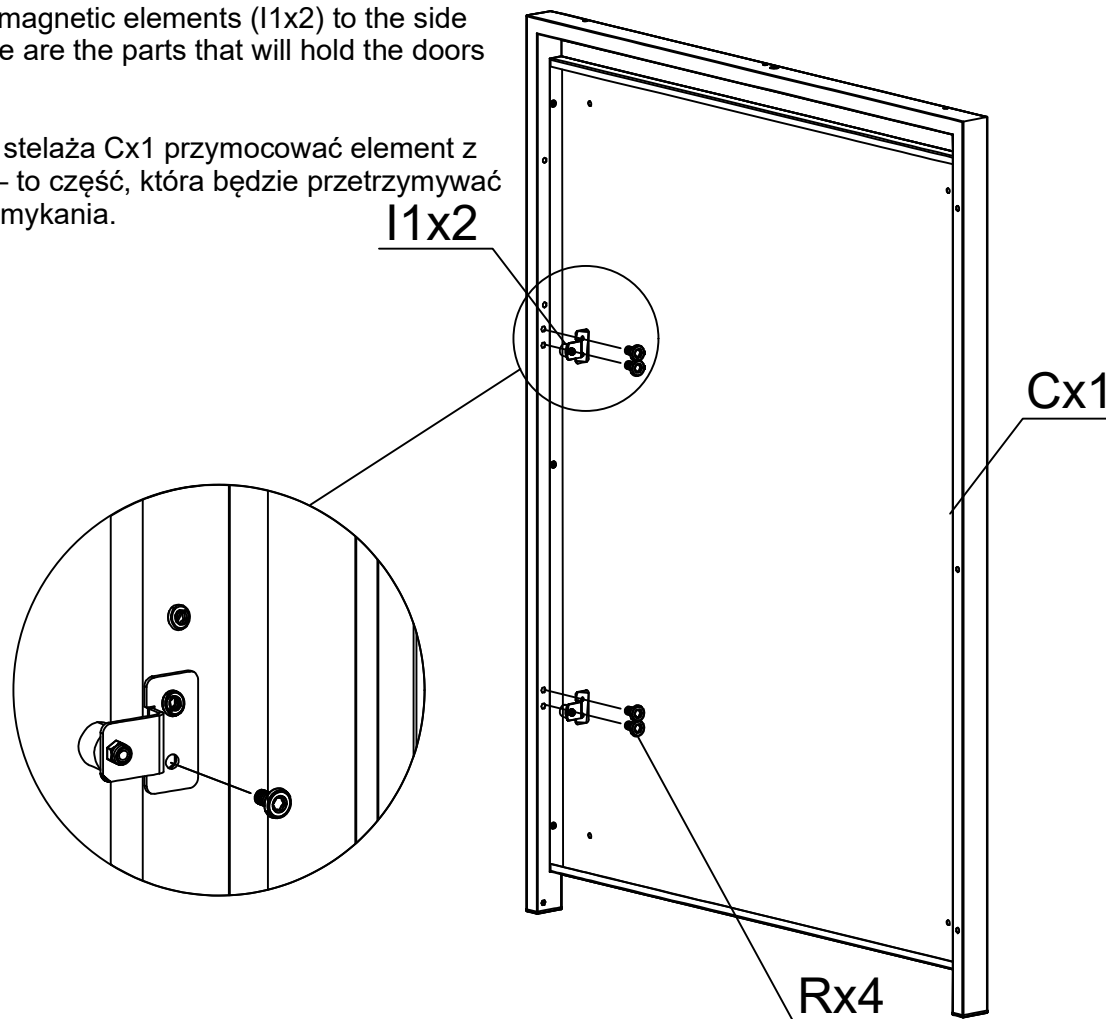

STEP 3

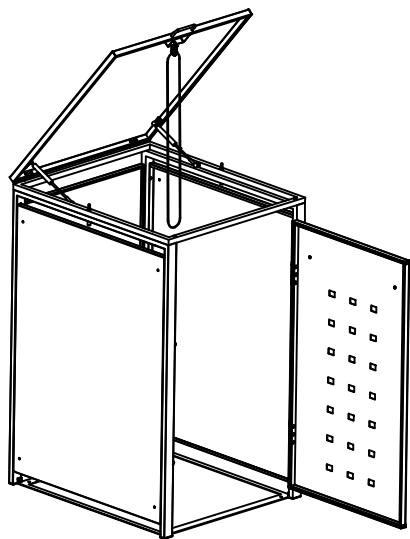
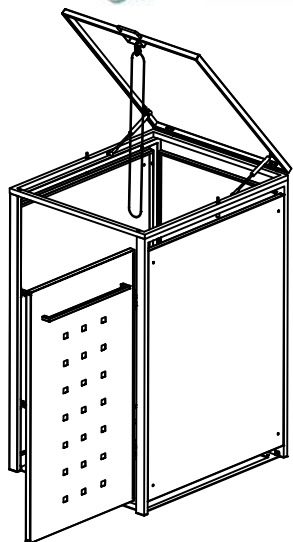

STEP 3:

DE: Befestigen Sie den mittleren Rahmen an der unteren Gehäuseteil, die die Basis der Metallabdeckung für den Mülleimer bildet. Schrauben Sie alles zusammen. Das Element Ax1 ist der untere Teil der Gehäusekonstruktion

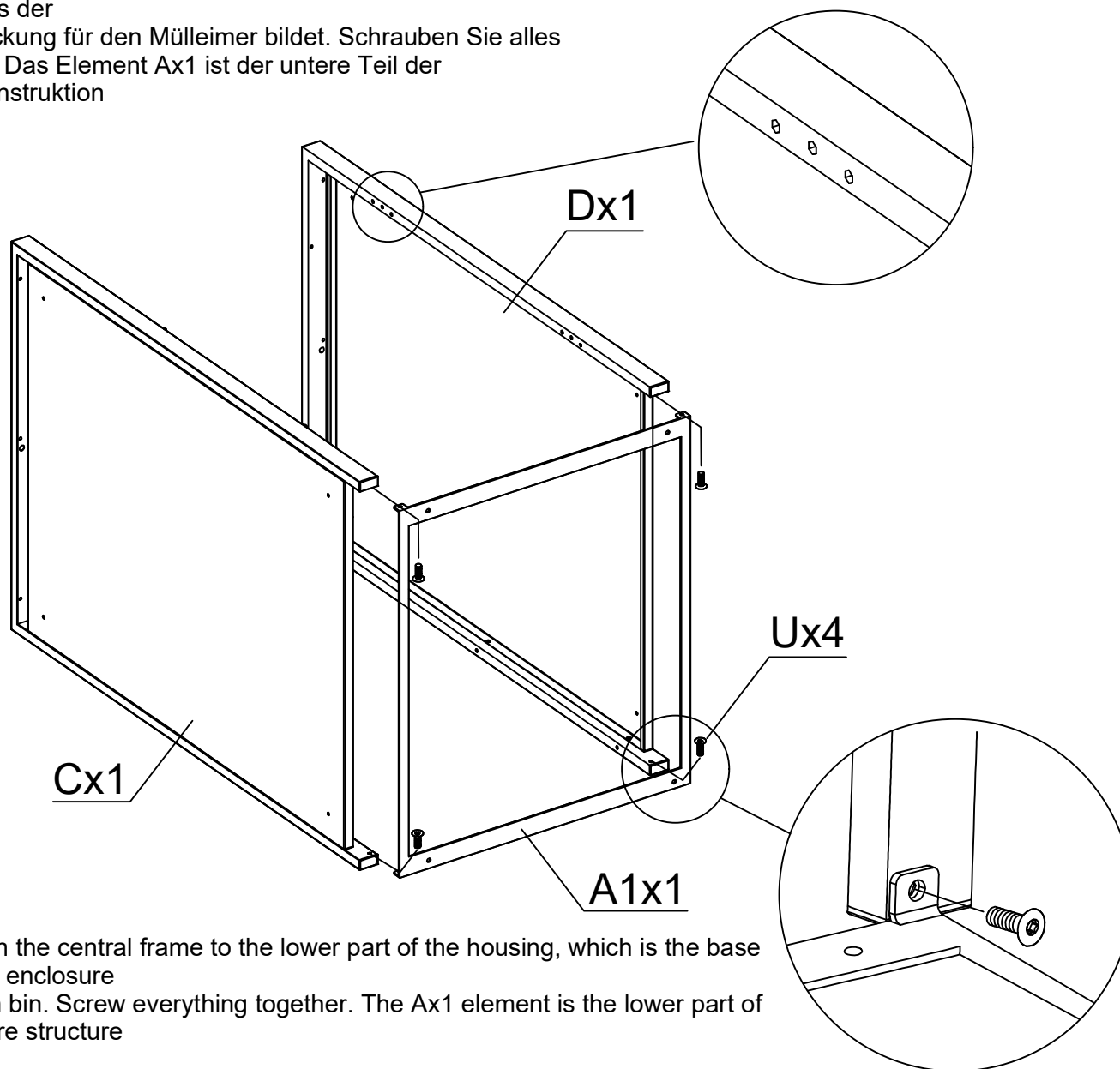

ENG: Attach the central frame to the lower part of the housing, which is the base of the metal enclosure for the trash bin. Screw everything together. The Ax1 element is the lower part of the enclosure structure

PL: Przymocować środkowy stelaż do dolnej części obudowy, która jest podstawą metalowej osłony na kosz na śmieci. Całość skrócić ze sobą. Element Ax1 jest dolną częścią konstrukcji obudowy.

STEP 4

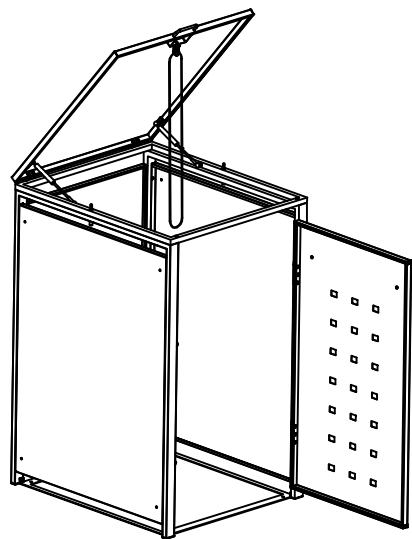
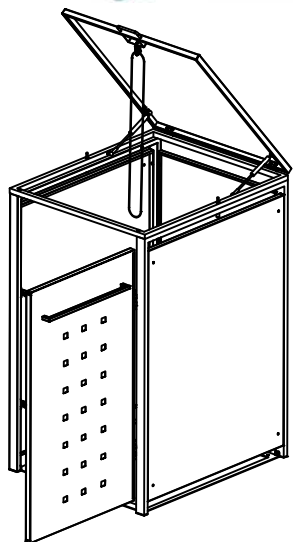

STEP 4:

DE: Befestigen Sie die Rückwand des Gehäuses für die Müllbehälter. Schieben Sie es zwischen die Rahmen und schrauben Sie es fest.

ENG: Attach the rear part of the housing for the bins. Insert it between the frames and screw it in place.

PL: Przymocować tylną część obudowy na kosze. Wsunąć między stelaż oraz przykręcić.

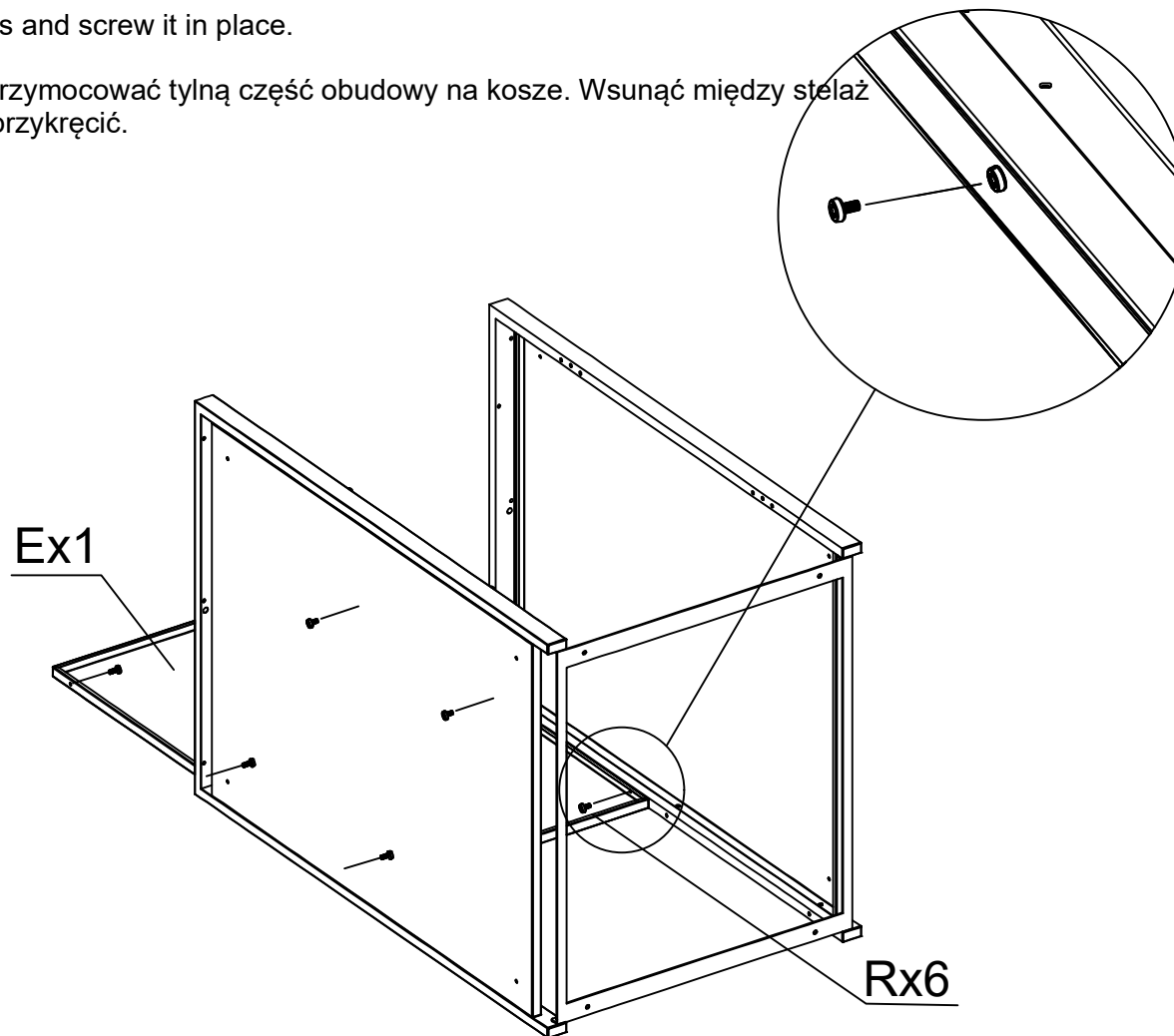

STEP 5

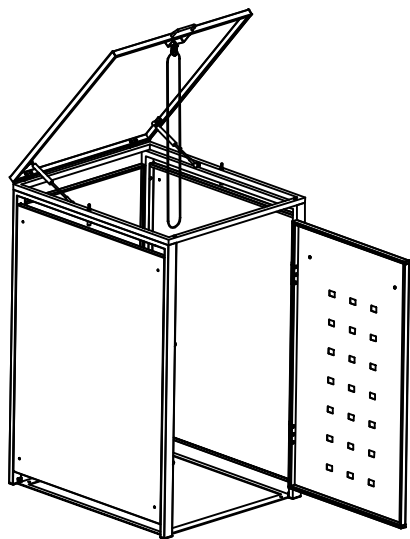
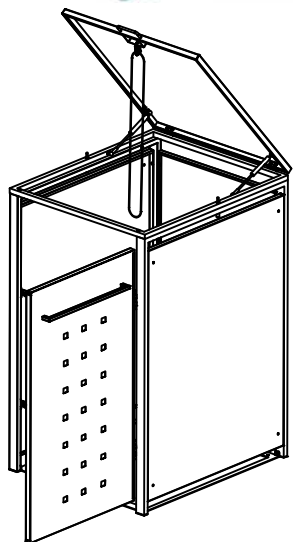

F1x1

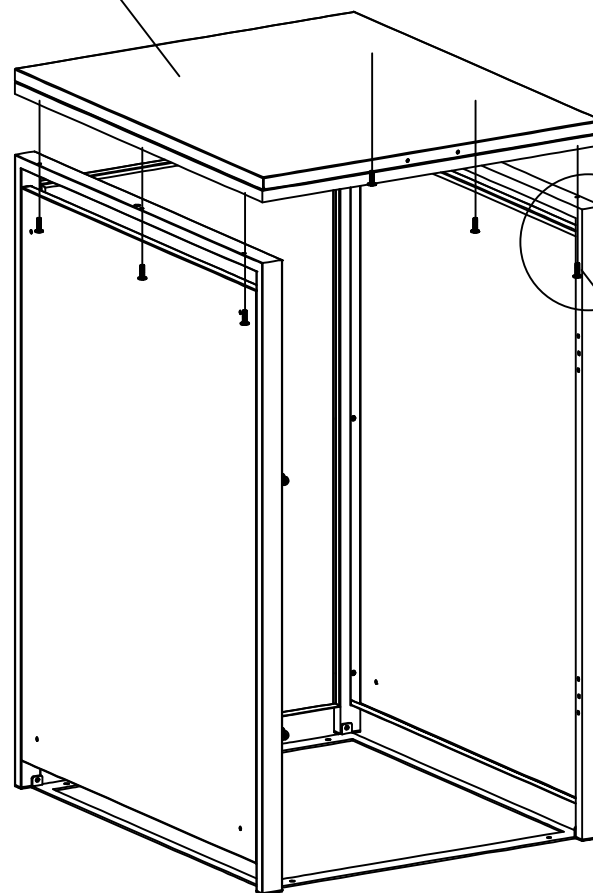

Tx6

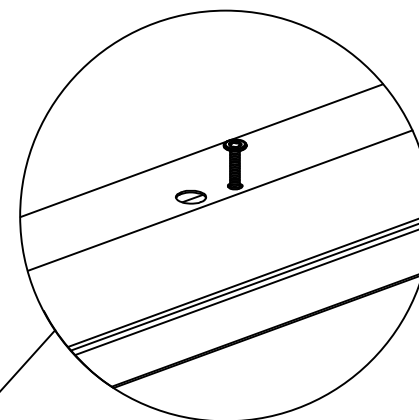

STEP 5:

DE: Stellen Sie den Rahmen aufrecht auf den Boden und montieren Sie die obere Klappe. Heben Sie sie zu zweit. Schrauben Sie sie fest.

ENG: Set the frame upright on the ground and mount the top lid. Lift it with two people. Screw it in place.

PL: Ustawić stelaż pionowo na ziemi i zamontować górną klapę otwieraną. Podnieść w dwie osoby. Przykręcić.

STEP 6

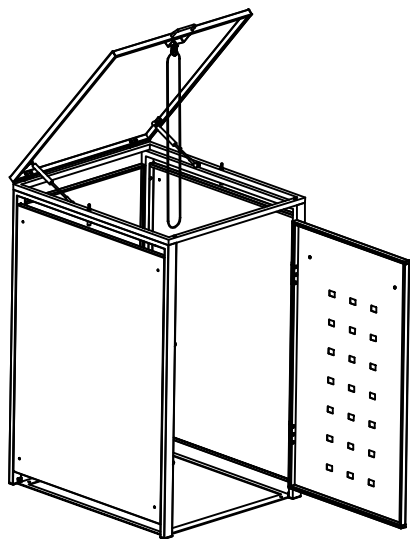
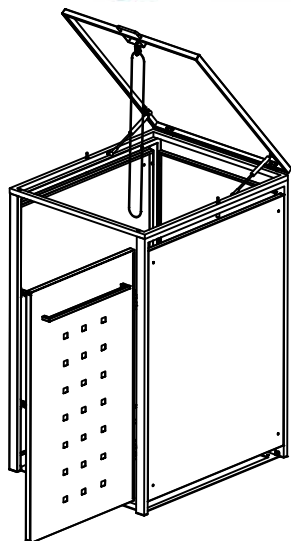

STEP 6:

DE: Montieren Sie 2 Türen, Scharniere und befestigen Sie sie am Rahmen. Die Türen benötigen keine Justierung.

ENG: Install 2 doors, hinges, and attach them to the frame. The doors do not require adjustment.

PL: Zamontować 2 sztuki drzwi, zawiasy i przymocować do stelaża. Drzwi nie wymagają regulacji.

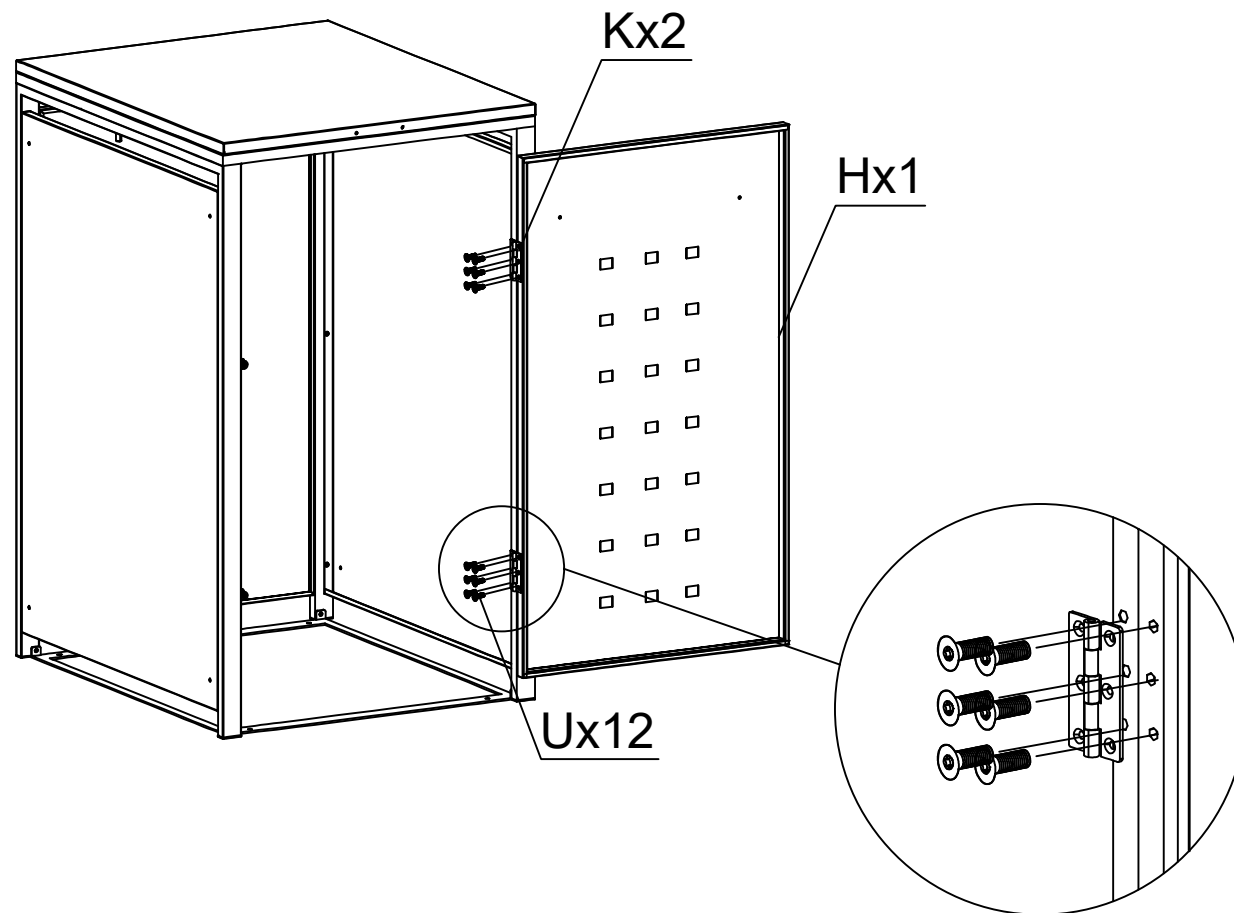

STEP 7



STEP 7:

DE: Befestigen Sie die Türgriffe

ENG: Install the door handles

PL: Zamontować rączkę do drzwi

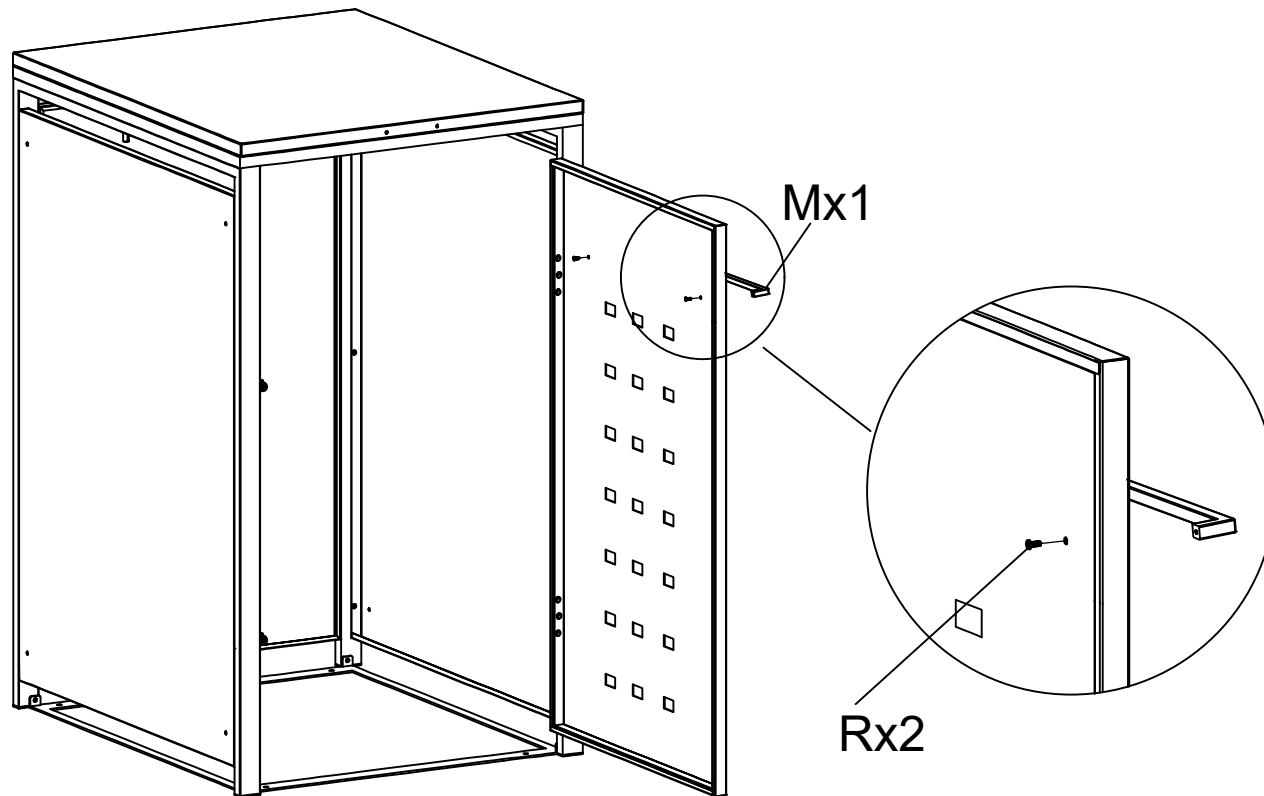
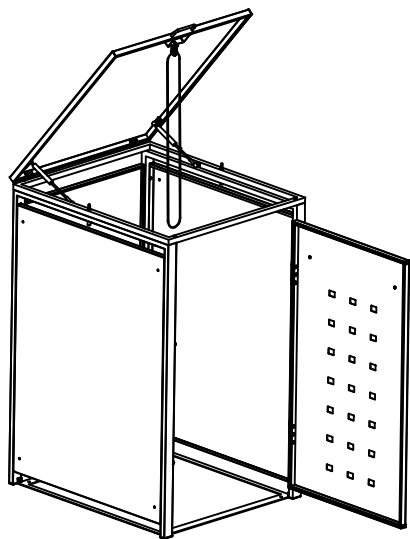
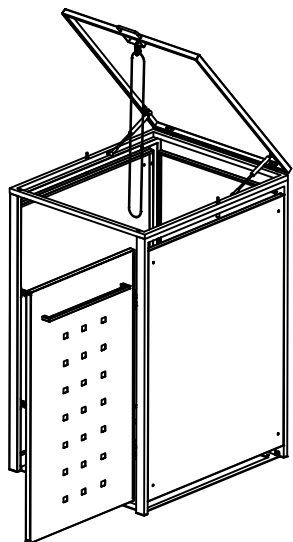

STEP 8

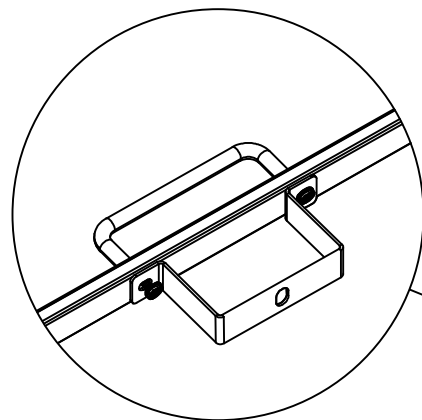
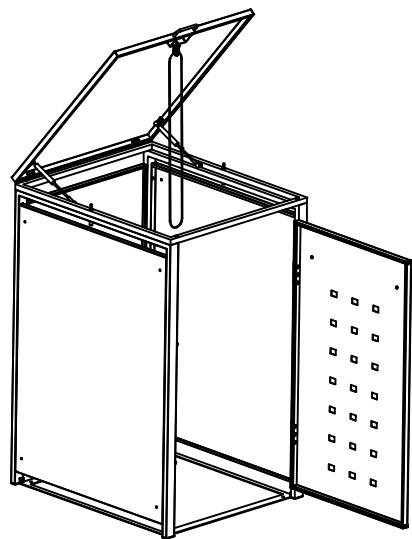
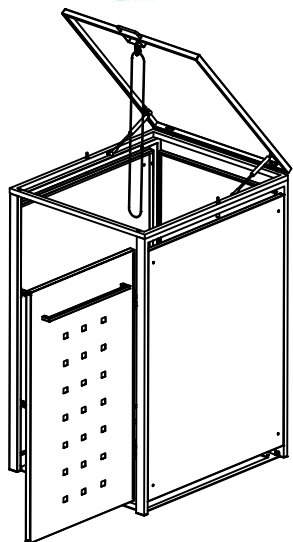

Sx2

Nx1

Ox1

Px2

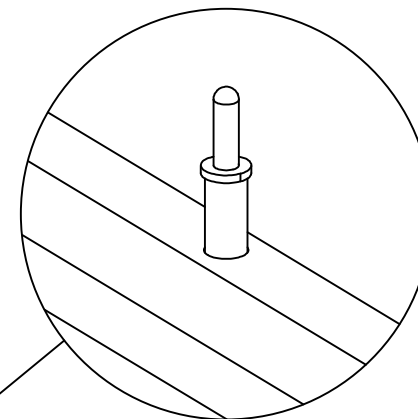

STEP 8:

DE: Montieren Sie die Griffe an der Einwurfklappe und die Stifte mit dem SoftClose-System (Ox4).

ENG: Install the handles on the drop-in lid and the pegs with the soft-close system (Ox4).

PL: Zamontować ręczki do kłapy wrzutowej oraz kołki z systemem wolnego opadania kłapy (Ox4).

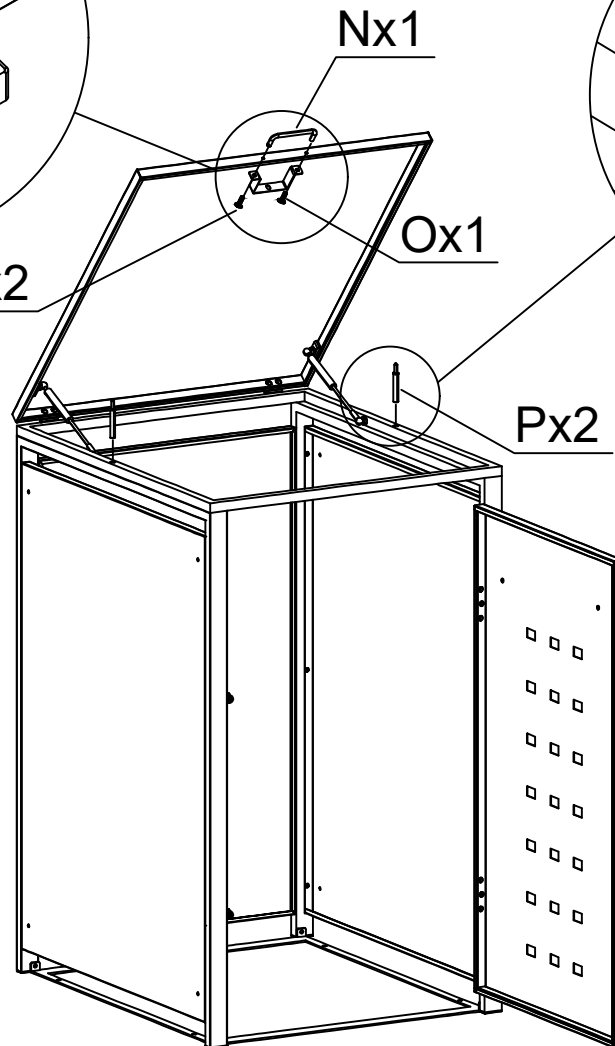

STEP 9

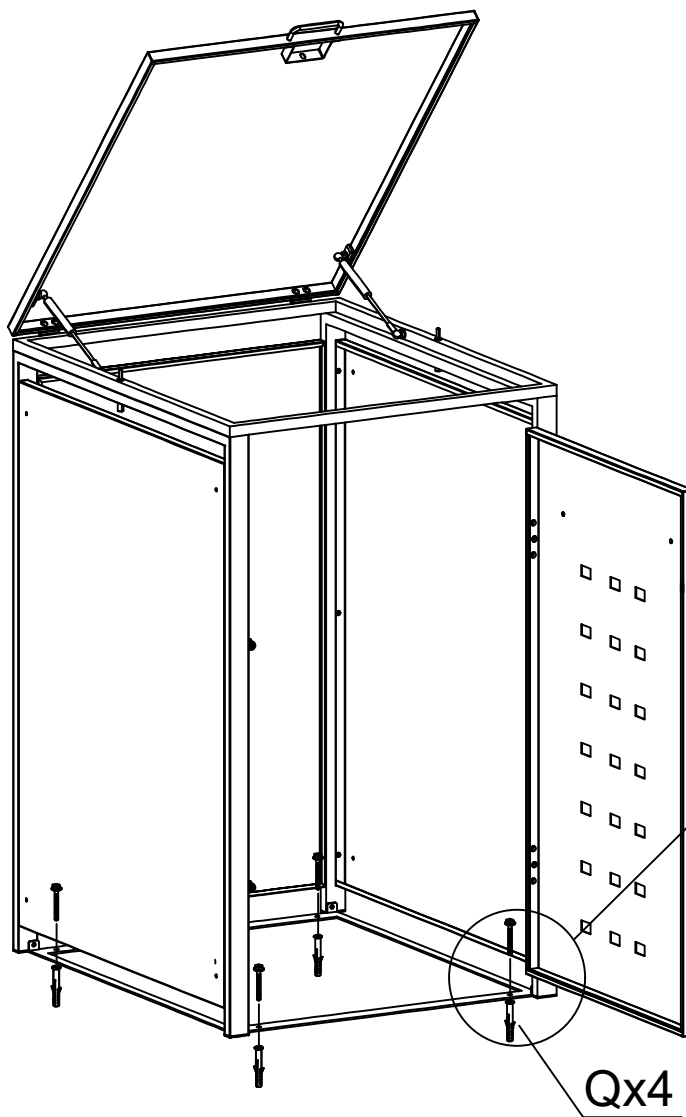
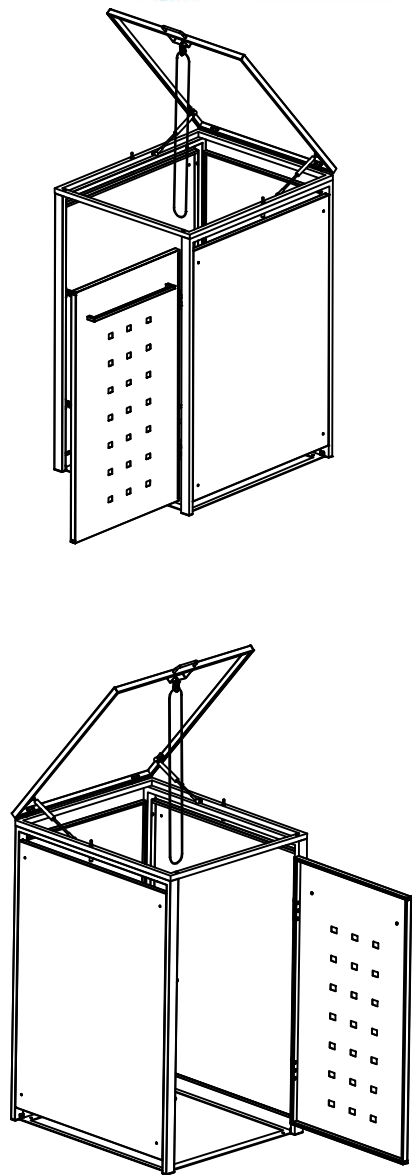

STEP 9:

DE: Verankern Sie den Behälter im Boden.

ENG: Anchor the container to the ground.

PL: Zakotwić pojemnik do gruntu

STEP 10

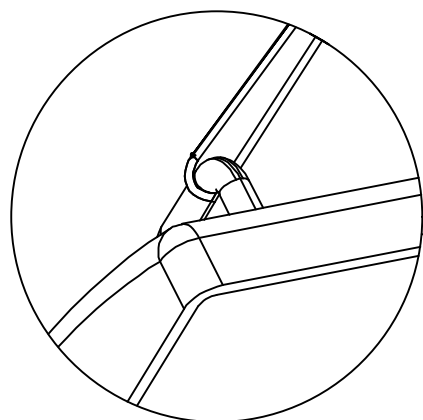

Vx1

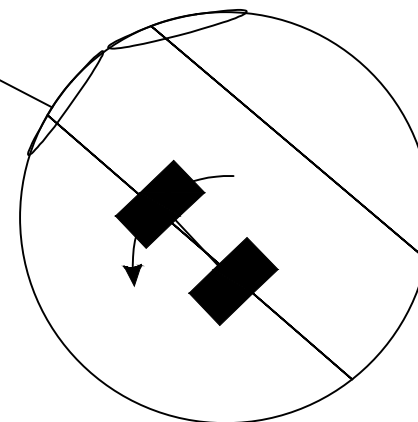
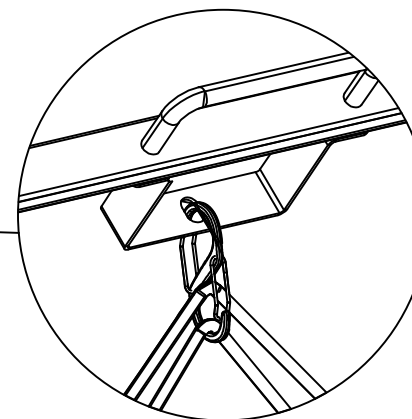
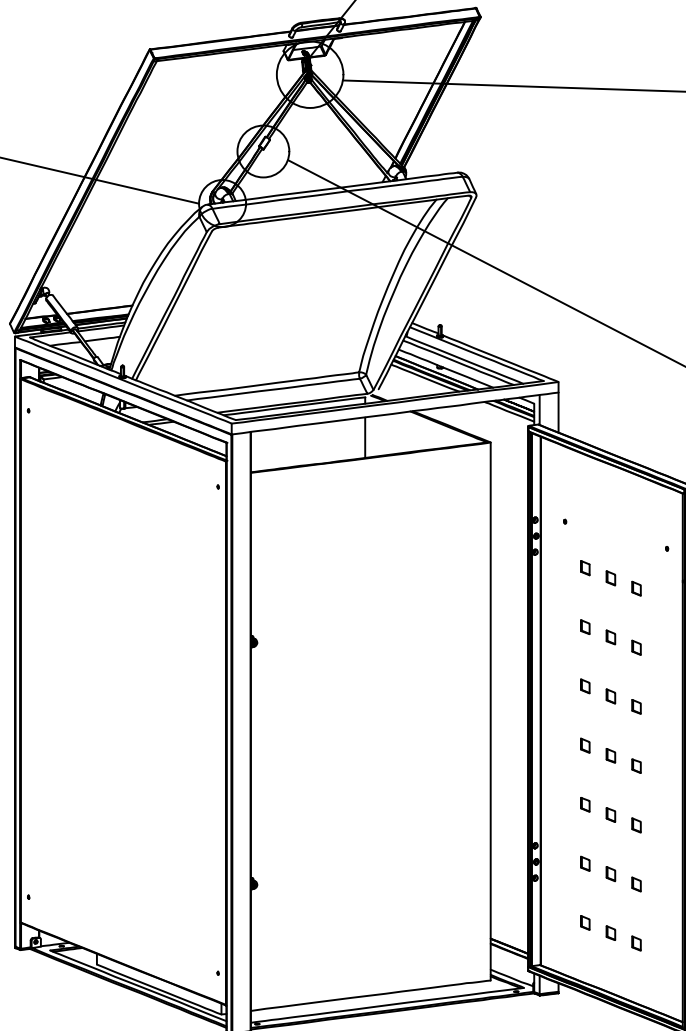

STEP 10:

DE: Befestigen Sie die Seile an der Klappe und verbinden Sie sie mit den Deckeln der Mülltonnen.

ENG: Attach the cables to the lid and connect them to the trash bin lids.

PL: Zamontować linki do kłapy i przytwierdzić je do kłapy od kubłów na śmieci.